

TELEMETRIX 400 WAVEFORM SIGNAL GENERATOR (T400TSS-I)

OVERVIEW

The RT Logic Telemetrix® 400 Waveform Signal Generator (T400TSS-I) is a modular software-defined telemetry simulator command formatter and signal generator. The system's flexible architecture allows the T400TSS-I to support many different signal simulation missions using an extensive standard feature set. All signal processing is performed in software and Field-Programmable Gate Arrays (FPGAs). The system is capable of telemetry simulation or command uplink processing. Standard operating frequencies include S-band and L-band, 70 MHz, and Baseband. Other frequency bands are supported through options.



APPLICATION

The T400TSS-I is well suited for testing telemetry subsystems within satellite ground stations, missile and satellite factories, and calibration laboratories. The T400TSS can be used as a replacement for legacy telemetry signal simulators or for new simulation applications. The standard packaging is a 2U high, 19-inch, rack-mount unit, with a 1U drawer with keyboard and flip-up monitor.

The highly modular and flexible architecture allows the T400TSS-I to support multiple encoding standards and modulation schemes, including FM, PM, FSK, BPSK, QPSK, OQPSK (SQPSK), UAQPSK, SOQPSK (MIL-STD and TG). Continuous frequency (Doppler) sweeping with selectable offsets and rates enables receiver testing against expected signal dynamics. Variable amplitude profiles enable further receiver testing for acquisition and lock thresholds, Automatic Gain Control (AGC) performance, and fading performance. Amplitude and phase profiles can be combined for accurate and repeatable fading tests. A built-in Bit Error Rate Tester (BERT), with clock and data inputs, is included for standalone testing of telemetry receivers.

The T400TSS-I can be controlled through the local RT Logic Graphical User Interface (GUI), using either a local monitor or over Ethernet using a networked computer. The unit can also be controlled from third-party software applications using documented Ethernet interfaces to the T400TSS-I software.

FEATURES

- L/S-Band, 70 MHz, Baseband Output Frequencies Standard, Other Bands Optional
- FM, PM, FSK, BPSK, QPSK, OQPSK (SQPSK), UAQPSK, SOQPSK (MIL-STD And TG)
- BPSK Subcarrier Phase Modulated Onto A Carrier
- Command Processing In USB (BPSK Subcarrier) Format
- PCM Encoding (Including NRZ-L, NRZ-M, NRZ-S, And BIO-L, BIO-M, BIO-S)
- Convolutional Encoding (Rate 1/2, K=7)
- Data Rates Up To 20 MSymbols/sec
- Continuous Doppler Simulation (20 MHz Range And Greater Than ± 100 kHz/sec Doppler Rate)
- Integrated BERT
- Realistic Simulation Of Propagation Path Effects When Integrated With The T400CS Channel Simulator

BLOCK DIAGRAM

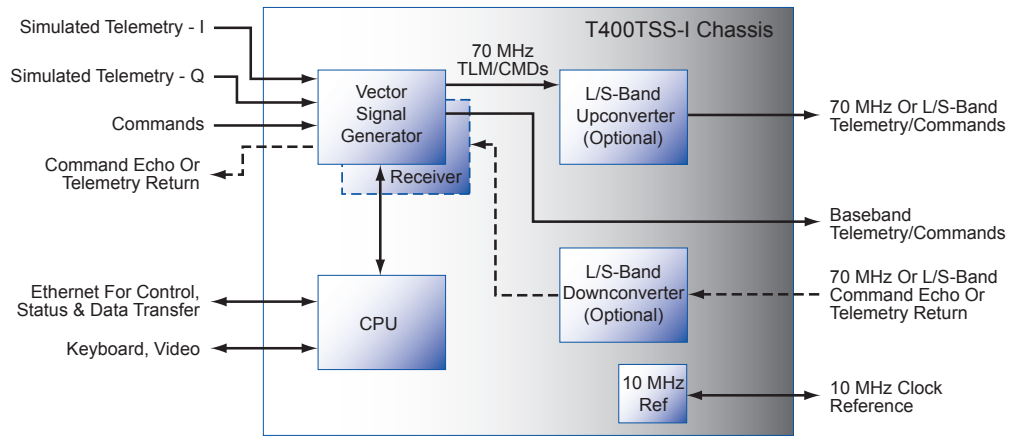

SPECIFICATIONS

- Telemetry Modulation
 - Modulation Types: PM, FM, AM, FSK (PCM/FM), BPSK, QPSK, OQPSK (SQPSK), UAQPSK, SOQPSK (MIL-STD), SOQPSK (TG)
 - Symbol Rates: Up To 20 Msps
 - Bandwidth: 40 MHz
 - Two PM Subcarriers
 - Subcarrier Modulation: BPSK
 - Subcarrier Frequency: 1 kHz To 19 MHz
- Command Generator/Modulator
 - BPSK Subcarrier (USB)
- Data Encoding
 - PCM Formats: NRZ-L, NRZ-M, NRZ-S, BIO-L, BIO-M, BIO-S, DBIO-M, DBIO-S, DM-M, DM-S
 - Data Rates: 10 bps To 20 Mbps NRZ, 10 bps To 10 Mbps Bi-Phase
 - Data Randomization
 - Convolutional Encoding: Rate $\frac{1}{2}$, K=7
- Pattern Generation
 - 15 Standard PRN Patterns (2^3 To 2^{23})
 - Constant Or Alternating 1/0
 - User Defined
 - Error Generation
 - User File With Looping
- Optional Receive
 - Command Echo Check
 - Loopback
- Intermediate Frequency Telemetry/Command Modulator
 - IF Output Frequency: 50 MHz To 90 MHz
 - Tuning Resolution: < 0.1 Hz
 - IF Output Level: -55 dBm To -5 dBm
- Radio Frequency Output
 - S-Band Agile Upconverter: 1650 MHz To 2400 MHz
 - RF Output Power: -115 dBm To +15 dBm
 - Gain Stability: ± 0.25 dB Over 24 Hours
- Carrier Sweeping
 - Profiles: Single Sweep, Triangle
 - Sweep Range: Continuous Within Modulation Bandwidth
 - Sweep Resolution: <0.1 Hz
 - Profiles Implemented With A Point And Slope Every Millisecond
- Amplitude Profiles
 - >30 dB Vernier Adjustment 0.01 dB Resolution
 - >90 dB Total Adjustment
- I/O
 - RF, IF, Or Baseband Output
 - I or Q Channel Simulated Telemetry Data And Clock Input (TTL Or RS-422)
 - Ternary Or Binary Command Data And Clock
 - Baseband Input For PM Or FM Modulation
 - Data And Clock Input To BERT
- Integrated BERT
 - 15 Standard PRN Patterns (2^3 To 2^{23})
- Frequency Reference Input
 - 5 MHz Or 10 MHz
- cPCI Processor Board
 - Flash Or Hard Disk
 - 10/100 Mbps Ethernet Interface
 - Monitor/Keyboard/Mouse Interface
- Control And Monitoring
 - Ethernet TCP/IP Remote M&C Interface
- Operating Environment
 - 0 °C To 50 °C
 - 10% To 90% Relative Humidity
- Storage Temperature
 - -10 °C To +60 °C
- Mechanical
 - 2U 19" Rack-Mount Unit